

A.L.T.A / A.C.S.M. Survey

Scale: 1" = 20'

Legend:
 P = Regular Parking Space
 C = Compact Parking Space
 HC = Handicap Parking Space

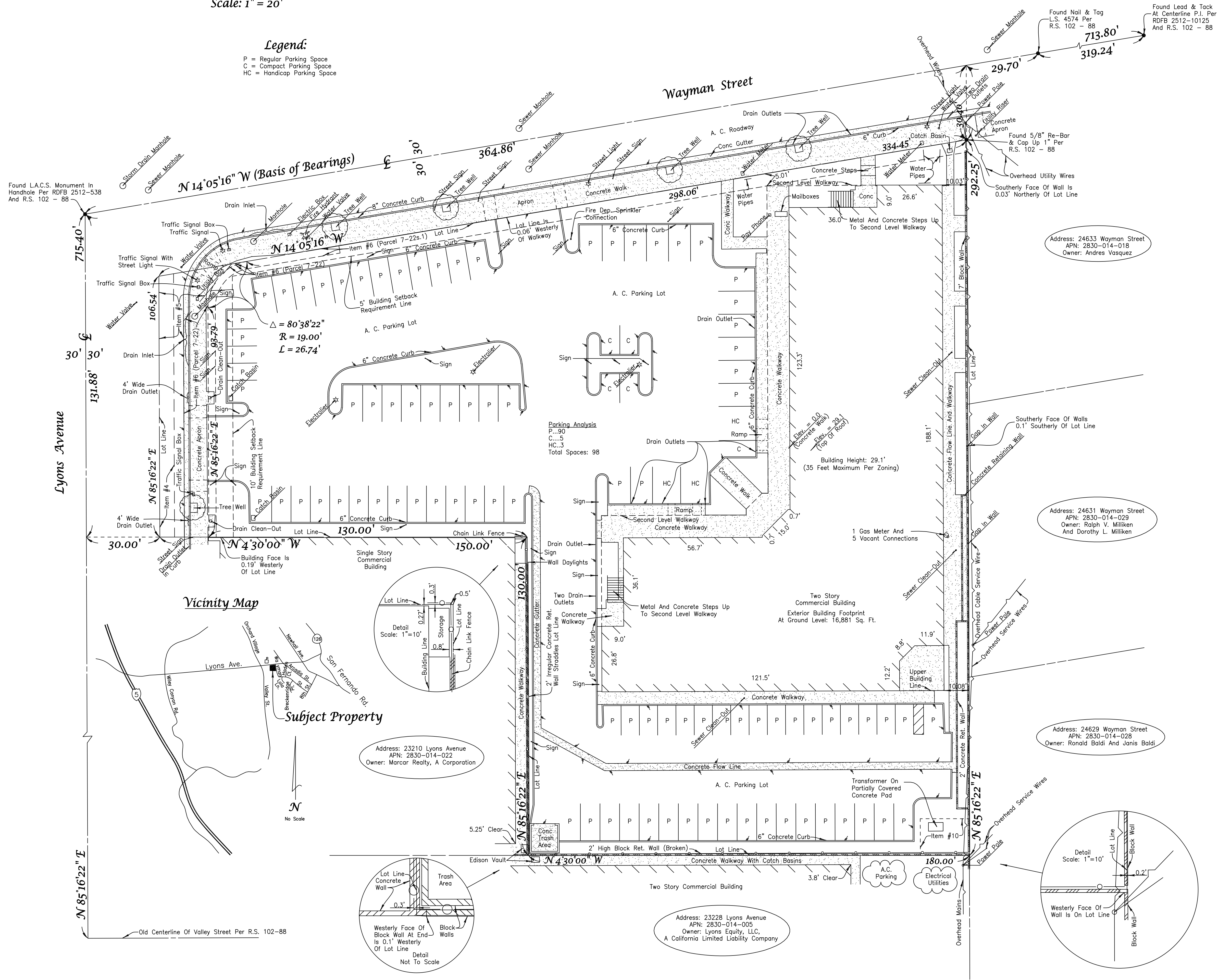

Found L.A.C.S. Monument In Handhole Per R.D.F.B. 2512-538 And R.S. 102 - 88

Found Nail & Tag L.S. 4574 Per R.S. 102 - 88
 Found Lead & Tag At Centerline P.I. Per R.D.F.B. 2512-10125 And R.S. 102 - 88

Address: 24633 Wayman Street
 APN: 2830-014-018
 Owner: Andres Vazquez

Address: 24631 Wayman Street
 APN: 2830-014-029
 Owner: Ralph V. Milliken And Dorothy L. Milliken

Address: 24629 Wayman Street
 APN: 2830-014-028
 Owner: Ronald Baldi And Janis Baldi

Address: 23210 Lyons Avenue
 APN: 2830-014-022
 Owner: Marcar Realty, A Corporation

Address: 23228 Lyons Avenue
 APN: 2830-014-005
 Owner: Lyons Equity, LLC, A California Limited Liability Company

Vicinity Map

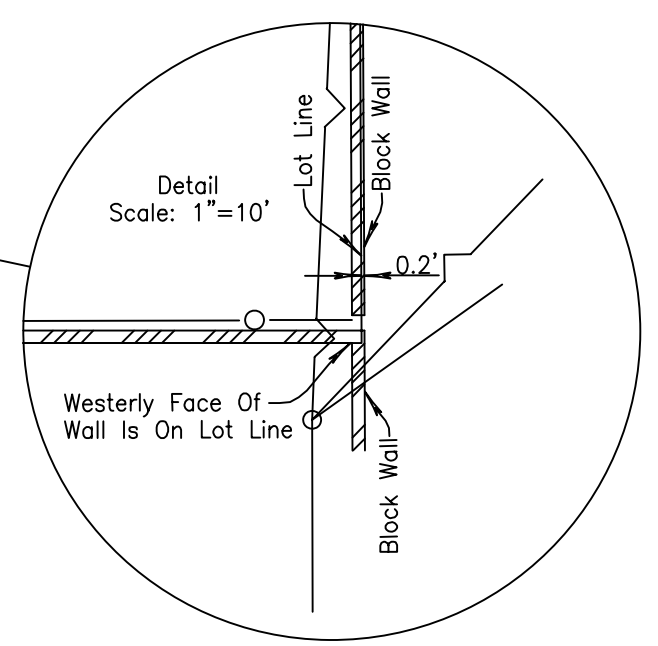
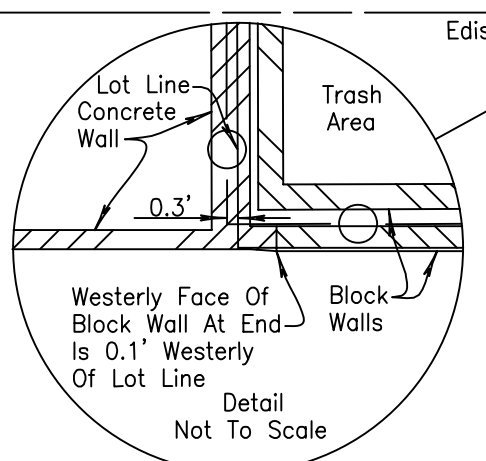
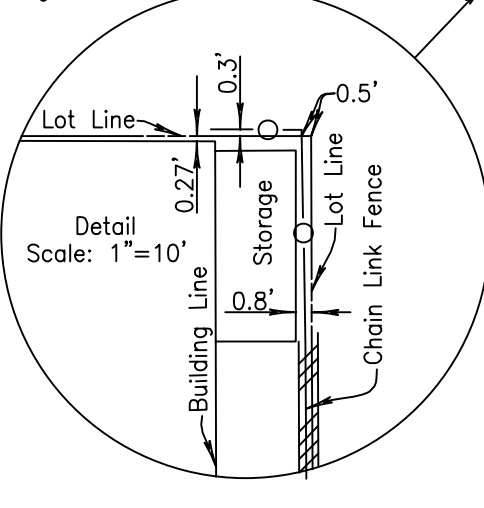
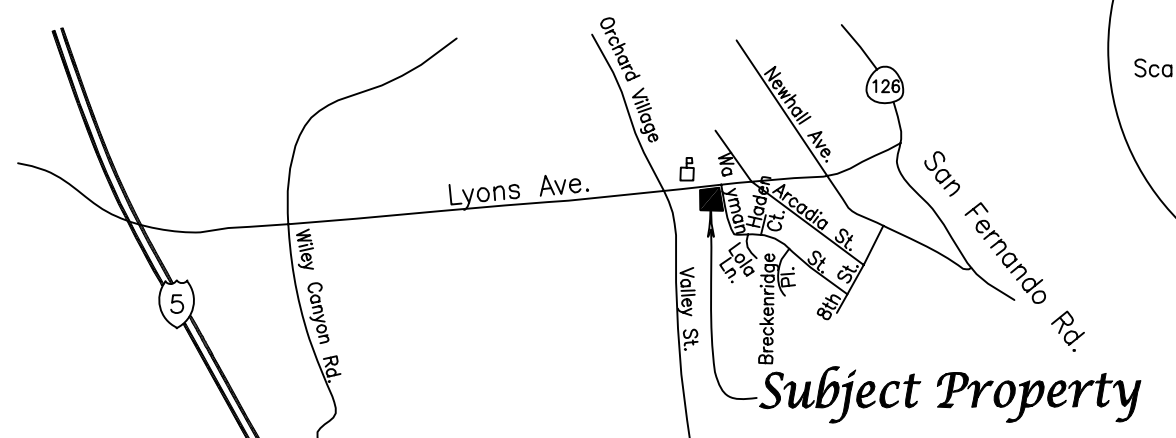

Parking Analysis
 P...90
 C...5
 HC...3
 Total Spaces: 98

Building Height: 29.1'
 (35 Feet Maximum Per Zoning)

Danielson Surveying
 Mark R. Danielson, L.S. 7882

28528 Constellation Road
 Valencia, CA 91355
 (661) 257-8828
 Fax (661) 257-8838
 E-mail: info@danielsonsurveying.com
 www.danielsonsurveying.com

Plan Prepared For:

Job # 03-71